

KingPo Technology Development Limited



**Luer Connector Test Fixture
Instruction Manual**

Please read this manual carefully before using the
instrument!

Table of Contents

- [1] Preface
 - [2] Safety Precautions
 - [3] Product Overview
 - [4] Overall Picture
 - [5] Technical Parameters
 - [6] Panel Description
 - [7] Operation Instructions
 - [8] Notes
 - [9] Packing List
 - [10] Quality Guarantee
 - [11] Product Warranty Card
 - [12] Certificate of Conformity
-

1 Preface

Thank you for choosing our products. We provide high-quality products and reliable after-sales service.

To ensure the personal safety of operators and the integrity of the instrument, please fully read this operation manual and strictly observe the precautions before use. This manual details the design principle, compliance standards, structure, operation specifications, maintenance, possible faults and troubleshooting, electrical diagrams and other contents of the instrument. All references to “test regulations” and “standards” in this manual are for reference only. Please consult relevant standards or materials if necessary.

Special Notes

- This manual shall not be used as a basis for any claims against our company.
- Our company reserves the right of interpretation of this manual.

Item: Luer Connector Test Fixture

Model: KP-3691

Production Date: August 2024

Manufacturer: Dongguan Jingbang Machinery Technology Co., Ltd.

2 Safety Precautions

Safety Symbols

This manual contains important safety precautions and instructions for instrument use. To prevent accidents and hazards, please strictly abide by the following markings of DANGER, WARNING and CAUTION:

DANGER:

Items marked with this symbol indicate that failure to comply may result in personal injury to the operator.

WARNING:

Items marked with this symbol indicate that failure to comply may damage the instrument.

CAUTION:

Items marked with this symbol indicate that the test results and quality may be affected.

3 Product Overview

Complies with GB1962.1, ISO80369 and other standards. It is used for testing assembly, separation force, unscrewing torque, anti-slip performance, ease of assembly, stress cracking and other properties of Luer connectors.

Complies with GB1962.1, ISO80369 and other standards. It is used for testing assembly, separation force, unscrewing torque, anti-slip performance, ease of assembly, stress cracking and other properties of Luer connectors.

4 Overall Picture



5 Main Technical Parameters

1. Technical Indicators

- Axial force weights: 20N, 26.5N, 27.5N, 35N
- Torque arm: 0.02m
- Torque weights: 0.9N (0.018N·m), 1N (0.02N·m), 6N (0.12N·m), 7.5N (0.15N·m), 8.5N (0.17N·m)

6 Structure Description

- Test Sample Connection Port
- Torque: Torque value can be adjusted by changing weights

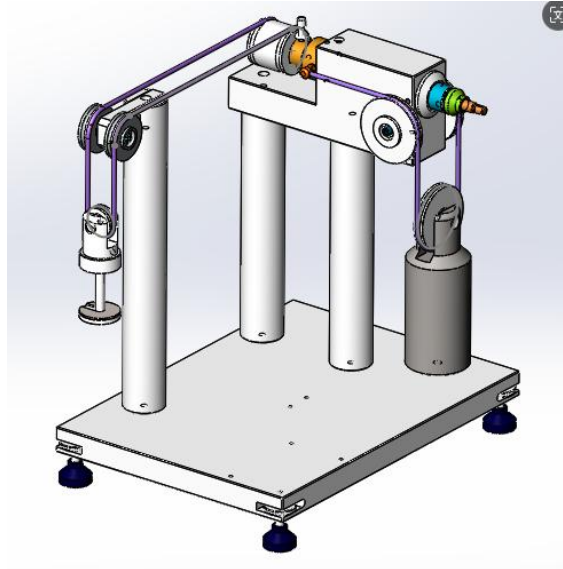

- Axial Force: Axial force value can be adjusted by changing weights
 - Feet: Used to level the equipment
-

7 Operation Instructions

7.1 Assembly

7.1.1 Select the test gauge and torque weight (0.08–0.12N·m)



7.1.2 Gently screw the sample into the gauge.



7.1.3 Insert the gauge into the sample test position of the equipment – hold the sample – push the sample to suspend the axial force weight – maintain the axial force and rotate the sample to suspend the torque weight – assembly completed



7.2 Unscrewing Torque Test

7.2.1 Assemble the gauge and test sample as required by the standard (see 7.1)

7.2.2 Select the 0.02N·m torque weight.



7.2.2 Wind the rope clockwise around the wheel.



7.2.3 Insert the slider into the axial force slot.



7.2.4 Insert the assembled sample into the device, release the torque shift lever, and apply 0.02N·m torque to the sample. Hold for at least 10 seconds.

7.2.5 Judgment: The sample shall not loosen.

7.3 Anti-Slip Performance Test

7.3.1 Assemble the gauge and test sample as required by the standard (see 7.1)

7.3.2 Insert the slider into the axial force slot.



7.3.3 Select a torque weight of 0.15–0.17N·m



7.3.4 Insert the assembled sample into the device, rotate the sample clockwise to apply torque, and hold for 5–10s



7.3.5 Judgment: The sample shall not slip

7.4 Ease of Assembly

Manually install the test connector onto the gauge. For semi-rigid material connectors, apply axial force not exceeding 20N and torque not exceeding 0.08N·m.

7.4.1 Select the test gauge, 0.08N·m torque weight and 20N axial force weight



7.4.2 Gently screw the sample into the gauge.

7.4.3 Insert the gauge into the sample test position – hold the sample – push the sample to suspend the axial force weight – maintain the axial force and rotate the sample to suspend the torque weight – take out the sample

7.4.4 Judgment: Check whether the sample is fully screwed into the gauge

7.5 Separation Force Test

7.5.1 Connect the test connector with the standard conical connector and assemble according to the assembly procedure in 7.1.

7.5.2 Select the 35N axial force weight

7.5.3 Pull the weight upward gradually to suspend it at a rate of 10N/s for no less than 10s in the direction away from the test fixture.

7.5.4 Judgment: The sample shall not separate from the gauge

7.6 Stress Cracking Test

7.6.1 Select the test gauge (GB/T 1962.2 – Figure 5 or Figure 7), thrust weight $\geq 27.5\text{N}$, torque weight $\geq 0.12\text{N}\cdot\text{m}$

7.6.2 Gently screw the sample into the gauge.



7.6.3 Insert the gauge into the sample test position – hold the sample – push the sample to suspend the axial force weight – maintain the axial force and rotate the sample to apply torque – hold for 5 seconds – assembly completed

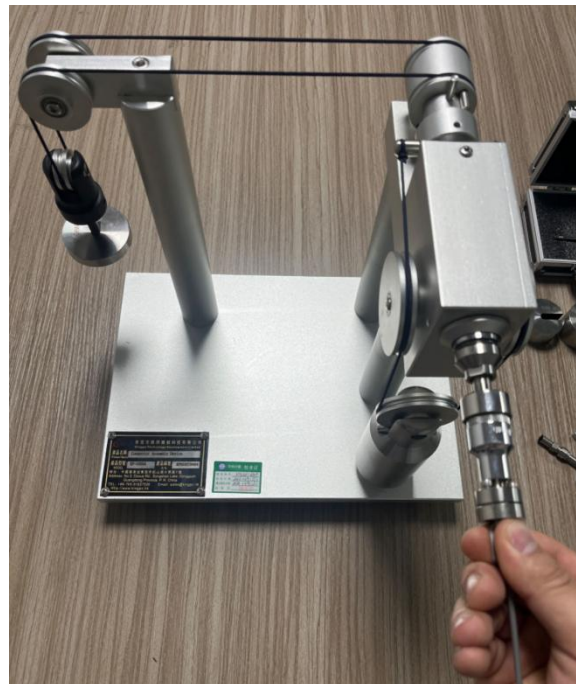

7.6.4 Place the assembled connector at $20^{\circ}\text{C} \pm 5^{\circ}\text{C}$ for $48\text{h} \pm 1\text{h}$

7.6.5 Judgment: The sample shall not crack

8 Notes

1. Handle with care; do not drop or throw.

2. If unused for a long time, clean regularly and apply anti-rust lubricant for anti-rust treatment.
 3. Storage conditions: Wipe off surface dust with clean gauze after use
 - a. Store in a dry environment at 20°C–25°C.
 - b. Keep away from acids, alkalis and other chemical substances and corrosive gases.
 4. Pre-use: Remove oil, dust, debris and other dirt to keep the equipment surface clean and bright.
 5. During use: Handle gently; do not apply impact force to the equipment to avoid damage. Tests must be carried out in strict accordance with standard specifications.
-

Packing List

Body No.: _____ Factory Date: _____ Packer: _____

No. Item Quantity

1 Luer Connector Test Fixture 1 set

2 Weights 1 set

3 Certificate of Conformity 1 copy

4 Warranty Card 1 copy

5 Instruction Manual 1 copy

The following is blank

Quality Guarantee

Warranty Period: _____

Item Model Body No.

This warranty card is valid for one year. Free repair is provided for defects in material or workmanship during the warranty period.

Item Model Body No.

This warranty card is valid for one year. Free repair is provided for defects in material or

workmanship during the warranty period.

Load sensors, displacement sensors and electromagnetic switches are not covered by the warranty.

Charges apply for repairs in the following cases:

1. Failure or damage caused by improper use.
2. Damage caused by assembly with non-original parts.
3. Failure caused by disassembly or repair by non-authorized personnel.

Warranty is void in the following cases:

1. Failure or damage caused by natural disasters or force majeure.
2. Damage caused by misuse or modification.
3. Failure caused by moving or transporting after installation.

If the warranty card is lost, the one-year warranty period starts from the factory date of the product.

Certificate of Conformity

KingPo Technology Development Limited.

Product Certificate

Model: KP-3691

Item: Luer Connector Test Fixture

Factory No.: _____

This product complies with relevant standards.

2024